

Rikaline GPS-6010-X5

【High Sensitivity】

GPS Receiver

User's Guide

Aug. 24, 2004



Rikaline International Corp.

14F, 171, ChengGong Rd., Sanchong City, Taipei 241, Taiwan, R.O.C

Phone: +886-2-8973-1899 Fax: +886-2-8973-1896

E-Mail: info@rikaline.com.tw Web: www.rikaline.com.tw

All Right Reserved

TABLE OF CONTENTS

0. Quick Use	3
0.1 Check GPS Package	3
0.2 Check Connector	3
0.3 Connect GPS-6010-X5 to your machine	3
0.4 Manufacturing Default	3
0.5 Important Features	3
0.6 Different Models	3
1. Introduction	4
1.1 Overview	4
1.2 Features	4
1.3 Technical Specifications	4
2. Operational Characteristics	6
2.1 Initialization	6
2.2 Navigation	6
3. Hardware Interface	7
3.1 Dimension	7
3.2 Hardware Interface	7
3.3 Connector	7
3.4 Accessories	7
4. USB Driver	10
4.1 System Requirement	10
4.2 Installation	10
4.3 Important	10
5. Warranty	10
Appendix A Software Interface	11
A.1 NMEA Transmitted Sentences	11
A.2 RTCM Received Data	14
Appendix B Earth Datums and Output Setting	15
B.1 Earth Datums	15
B.2 Setting	15
Appendix C Products Information	16
C.1 Product Options	16
C.2 Accessories	16
C.3 Products Combination	16

0. Quick Use

0.1 Check GPS Package

0.1.1 Standard Package

GPS-6010-X5 (GPS Receiver) + Documents CD + Warranty Card + quick installation reference.

0.1.2 Optional Package

The shop may bundle different accessories for you as follows:

1. PC Cable
2. PDA Cable
3. PDA Holder
4. Software (Navigation Software + Digital Map)
5. Others

0.2 Check connector

1. A-6011 RS-232 Serial Port Connector
2. A-6013 USB Connector, Please install USB driver first.
3. When you connect your PDA to GPS-6010-X5, you need an optional cable. Check the **e mark (FCC)** for safety and ensure the cigarette adapter with correct model number to avoid damaging your PDA.
4. Various cables are ready for your devices.

0.3 Connect GPS-6010 to your machine.

Turn on your machine and execute the navigation software.

0.4 Manufacturing Default

1. Sentence: GGA, GSA, GSV, RMC, VTG
2. Baud Rate: 4800
3. Datum: WGS84
4. WAAS: OFF

0.5 Important Features

1. With SiRF IIe Xtrac high sensitivity software, Xtrac II for series starts from, xxxxxxxxxx
2. Water proof for 1 meter
3. Built-in magnets for using on top of the car up to speed of 240km per hour without sliding.
4. Operating temperature range from -40°C to +85°C (internal temperature)

0.6 Different Models

1. GPS-6010-X5: with PS-2 connector, with RS-232 and TTL dual levels.
2. GPS-6010-UX5: with A type USB connector.

1. Introduction

1.1 Overview

The *Rikaline* **GPS-6010-X5 Smart Antenna** is a total solution GPS receiver, designed based on **SiRF Star IIe** Architecture with the newest Xtrac II **high sensitivity** system. This revolutionary system provides you unbelievable positioning sensitivity allowing you to have easy position fix in urban canyon conditions. This positioning application meets strict needs such as car navigation, mapping, surveying, security, agriculture and so on. Only clear view of sky and certain power supply are necessary to the unit. It communicates with other electronic utilities via compatible dual-channel through RS-232 or TTL and saves critical satellite data by built-in backup memory. With low power consumption, the **GPS-6010-X5** tracks up to 12 satellites at a time, re-acquires satellite signals in 100 ms and updates position data every second. Trickle-Power allows the unit operates a fraction of the time and Push-to-Fix permits user to have a quick position fix even though the receiver usually stays off.

1.2 Features

The GPS-6010-X5 provides a host of features that make it easy for integration and use.

1. **SiRF Star II** chipset with embedded ARM7TDMI CPU available for customized applications in firmware.
2. High performance receiver tracks up to 12 satellites while providing first fast fix and low power consumption.
3. Compact design ideal for applications with minimal space.
4. A rechargeable battery sustains internal clock and memory. It is recharged during normal operation.
5. User initialization is not required.
6. Dual communication channels and user selectable baud rates allow maximum interface capability and flexibility.
7. Dual communication levels, RS-232 and TTL meet ordinary application and PDA navigation.
8. FLASH based program memory: New software revisions upgradeable through serial interface.
9. LED display status: The LED provides users visible status. LED "ON" when power connected.
10. Built-in WAAS / EGNOS demodulator.
11. Built-in Magnets for using on top of car.
12. Water proof (1 meter) design for all weather.

1.3 Technology specifications

1.3.1 Physical Dimension

Single construction integrated antenna/receiver.
Size: 59.0(W) x 51.0 (47.3)(D) x 20.6(H) (mm)
2.32"(W) x 2.00"(1.86)(D) x 0.81"(H).

1.3.2 Environmental Characteristics

- 1) Operating temperature: -40°C to +85°C(internal temperature).
- 2) Storage temperature: -55°C to +100°C.

1.3.3 Electrical Characteristics

- 1) Input voltage: +4.75 ~ 5.5 VDC without accessories.
+6 ~ 30VDC with accessory A-6014.
- 2) Backup power: 3V Rechargeable Lithium cell battery, up to 767 hours (31.9 days) discharge.

1.3.4 Performance

- 1) Tracks up to 12 satellites.
- 2) Update rate: 1 second.
- 3) Acquisition time
Reacquisition 0.1 sec., averaged
Hot start 8 sec., averaged

- Warm start 38 sec., averaged
Cold start 45 sec., averaged
- 4) Position accuracy:
- A) Non DGPS (Differential GPS)
- | | |
|----------|-------------------------------------|
| Position | 5-25 meter CEP with SA off |
| Velocity | 0.1 meters/second, with SA off |
| Time | 1 microsecond synchronized GPS time |
- B) DGPS (Differential GPS)
- | | |
|----------|-----------------------------|
| Position | 1 to 5 meter, typical |
| Velocity | 0.05 meters/second, typical |
- 5) Dynamic Conditions:
- | | |
|--------------|--------------------------------------|
| Altitude | 18,000 meters (60,000 feet) max |
| Velocity | 515 meters / second (1000 knots) max |
| Acceleration | 4 G, max |
| Jerk | 20 meters/second ³ , max |

(DGPS function built by demand)

1.3.5 Interfaces

- 1) Dual channel RS-232 or TTL compatible level, with user selectable baud rate (4800-Default, 9600, 19200, 38400, 57600).
- 2) NMEA 0183 Version 2.2 ASCII output (GPGGA, GPGLL, GPGSA, GPGSV, GPRMC, GPVTG).
- 3) Real-time Differential Correction input (RTCM SC-104 message types 1, 5 and 9).
- 4) SiRF protocol.

2. Operational characteristics

2.1 Initialization

As soon as the initial self-test is complete, the GPS-6010-X5 begins the process of satellite acquisition and tracking automatically. Under normal circumstances, it takes approximately 45 seconds to achieve a position fix, 38 seconds if ephemeris data is known. After a position fix has been calculated, information about valid position, velocity and time is transmitted over the output channel.

The GPS-6010-X5 utilizes initial data, such as last stored position, date, time and satellite orbital data, to achieve maximum acquisition performance. If significant inaccuracy exists in the initial data, or the orbital data is obsolete, it may take more time to achieve a navigation solution. The GPS-6010-X5 Auto-locate feature is capable of automatically determining a navigation solution without intervention from the host system. However, acquisition performance can be improved when the host system initializes the GPS-6010-X5 in the following situation:

- 1) Moving further than 1,500 kilometers.
- 2) Failure of data storage due to the inactive internal memory battery.

2.2 Navigation

After the acquisition process is complete, the GPS-6010-X5 sends valid navigation information over output channels. These data include:

- 1) Latitude/longitude/altitude
- 2) Velocity
- 3) Date/time
- 4) Error estimates
- 5) Satellite and receiver status

The GPS-6010-X5 sets the default of auto-searching for real-time differential corrections in RTCM SC-104 standard format, with the message types 1, 5, or 9. It accomplishes the satellite data to generate a differential (DGPS) solution. The host system, at its option, may also command the GPS-6010-X5 to output a position whenever a differential solution is available.

3. Hardware interface

3.1 Dimension

Size: 59.0(W) x 51.0 (47.3)(D) x 20.6(H) (mm)
2.32"(W) x 2.00"(1.86)(D) x 0.81"(H).

3.2 Hardware Interface

The GPS-6010-X5 includes an antenna in a unique style waterproof gadget. Simply connect PS-2 female connector to one of the optional accessories and link to either your notebook PC, PDA or other devices. The one-piece cigarette adapter allows you to connect GPS-6010-X5 to your PDAs. Optional color, input voltage and output connector are listed and described below:

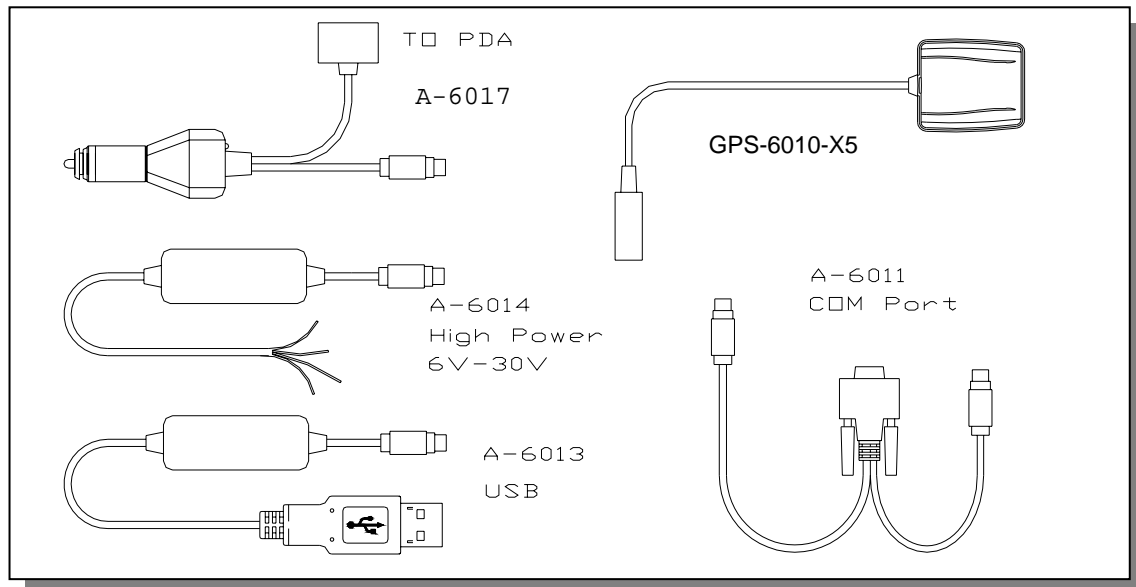

3.3 Connector

Standard cable: 2 meters with female PS-2 connector.

The GPS-6010-X5 is also equipped with optional customized connectors.

3.3.1 Function definition of standard female PS-2 composite connector

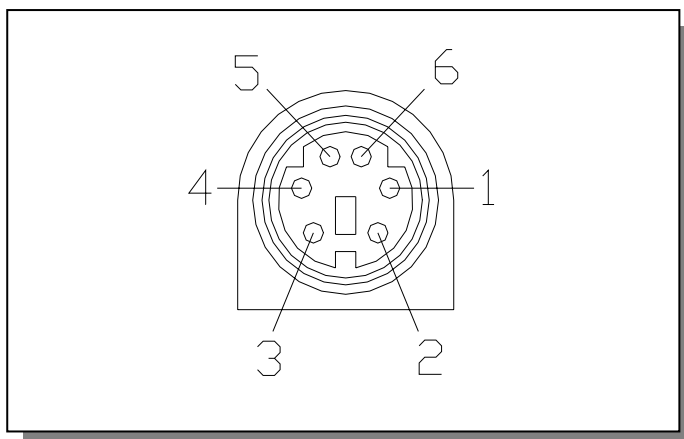

Pin	Signal
1	Tx (RS-232)
2	+5VDC
3	Tx (TTL)
4	Ground
5	Rx (TTL)
6	Rx (RS-232)

3.4 Accessories

3.4.1 A-6011 Mini Din Female and PS-2 male connector:

Cable Length: To GPS-6010-X5: 1 meter
 RS-232 to PS-2: 45 cm

Note: PS-2 with long cable (1 meter) is for GPS
 PS-2 with short cable (45mm) is for power

3.4.1.1 Mini Din Female connector function definition:

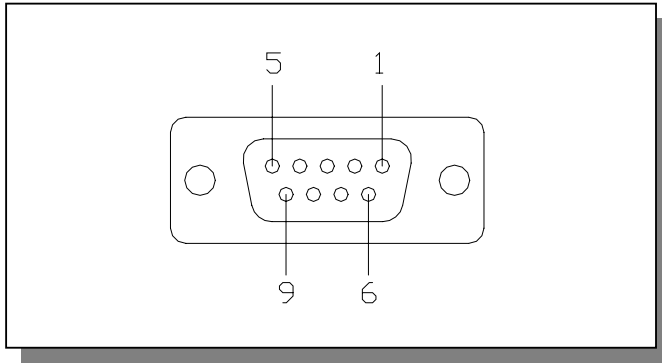

Pin	Signal Name
1	N.C
2	Tx
3	Rx
4	N.C
5	Ground
6	N.C
7	N.C
8	N.C
9	DGPS in

N.C = No connection

3.4.1.2 PS-2 male connector function definition (to PC):

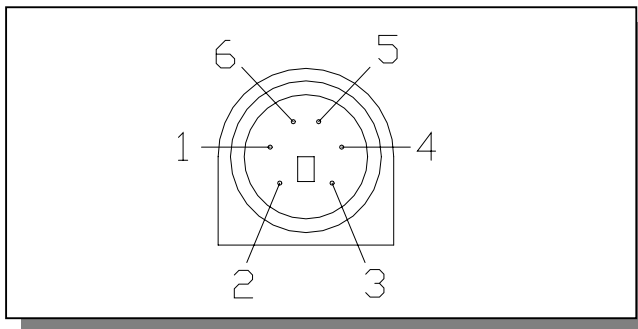

Pin	Signal Name
1	+5V
2	N.C
3	N.C
4	Ground
5	N.C
6	N.C

N.C = No connection

Remarks: **A-6011-S** is for COM+PS-2 converting to PS-2 female. If you have an old GPS receiver with standard COM + PS-2 male connector, you may choose an A-6011-S. Then you can use your old GPS receiver with PDA or USB version PC. Casio PDAs is excluded.

3.4.2 A-6013 USB connector

The function definition of the A Type USB connector is as follows:

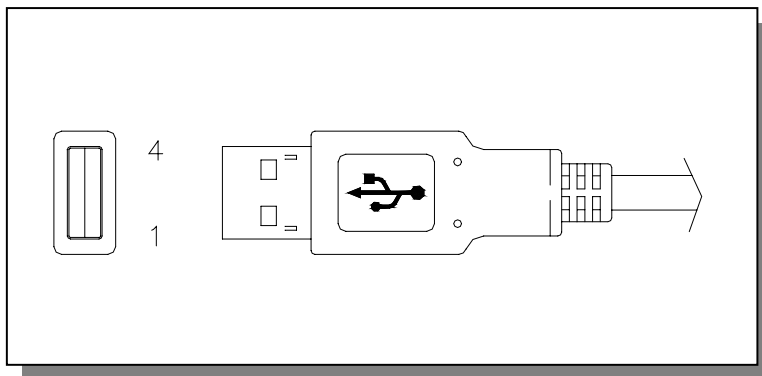

Pin	Signal Name
1	+5V
2	D +
3	D -
4	Ground

Remarks: **A-6013-C** is for COM+PS-2 converting to USB

If you have an old GPS receiver with standard COM + PS-2 male connector, you may choose an A-6013-C. Then you can use your old GPS receiver with USB version PC.

3.4.3 A-6014 High power connector

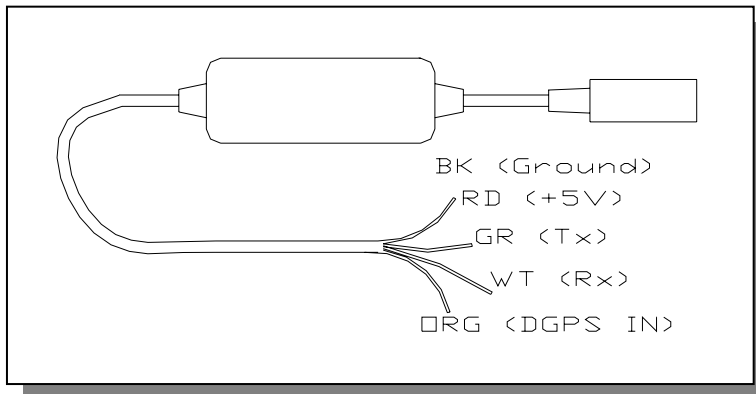

Color	Signal
Black	Ground
Red	+6~30 VDC
Green	Tx
White	Rx
Orange	DGPS IN

3.4.4 A-6015 Mounting Bracket

For using GPS-6010-X5 on a boat or somewhere no metal to facilitate the magnets, you need a mounting bracket to fix the GPS receiver. Simply fasten 3 screws (3 screws for metal and 3 for wood are Enclosed) through the holes of the bracket when using it as a GPS holder.

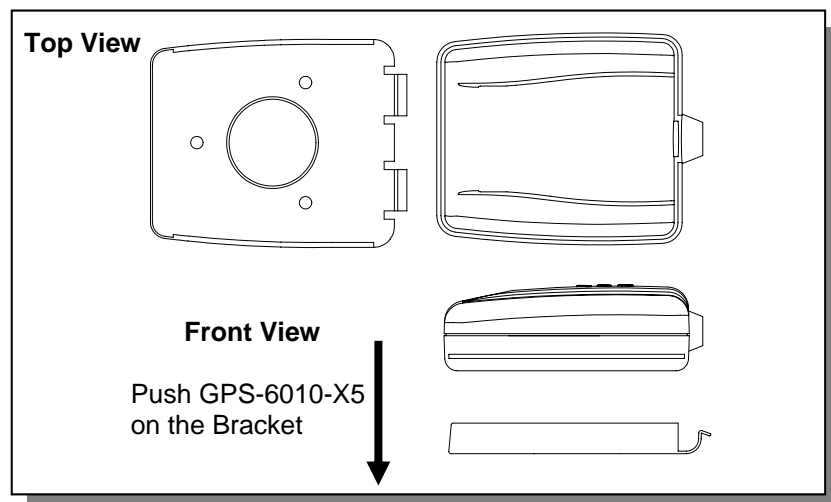

It becomes a Mounting Bracket only for series no. starting **from 60120000**. The magnets are built in the main housing. Fasten 3 screws (Enclosed) through the holes of the bracket when using it as a GPS holder.

3.4.4 A-6016 Optional Cigarette Adapter

The optional cigarette adapter with 2-meter core cable is for using in a car or boat. It must be used together with an A-6011 or an old standard COM + PS-2 GPS receiver. Input voltage: DC12V - 26V

3.4.5 A-6017 Cigarette adapter and PDA connector:

Part No.	Application	Part No.	Application
A-6017-A	ASUA	A-6017-LS	Lenovo
A-6017-AR	ACER S series	A-6017-M	Mitac Mio
A-6017-B	BESTA I-WINNA	A-6017-N	NEC
A-6017-C	Casio	A-6017-P	Palm
A-6017-D	Dell Axim	A-6017-Q	I-Paq
A-6017-E	Eten	A-6017-S	Sony Series
A-6012-G	GSL Xplore	A-6017-SM	Siemens SX-45

High Sensitivity

GPS-6010-X5 Operating Manual

Rikaline

A-6017-H
A-6017-L

HP Jornada
Siemens LOOX

A-6017-T
A-6017-X

Toshiba Series
O2-XDA / T-Mobile – MDA

Please find details in page 16

4. USB Driver

4.1 System Requirements

IBM, Pentium or above and other compatible PC; 16 MB and above memory; Windows 98/Me/2000; VGA Graphic Adapter.

4.2 Installation

1. Copy entire <GPS-6010-X5 USB> folder from CD to hard disk.
2. Connect GPS-6010-X5 USB connector to computer. While the computer automatically starts the installation program, please direct the driver to the <GPS-6010-X5 USB> folder.
3. After the installation is complete, go to <Device Manager> and select <Ports (COM & LPT)> to verify if a virtual COM port <USB to Serial Port> was created.

4.3 Other Operation System

1. Copy entire <GPS-6010 USB> folder from CD to hard disk.
2. Connect GPS-6010 USB connector to computer. While the computer automatically starts the installation program, please direct the driver to the <GPS-6010 USB> folder.
3. After the installation is complete, go to <Device Manager> and select <Ports (COM & LPT)> to verify if a virtual COM port <USB to Serial Port> was created.

4.3 Other Operation System

4.3.1 Linux RedHat 7.3

4.3.2 MaxOS 8.6, 9.x, 10.1.x ~ 10.3.3

4.3.3 Pocket PC

Details in the documents CD

5. Warranty

The GPS-6010-X5 is warranted to be free from defects in material and functions for one year from the date of purchase. Any failure of this product within this period under normal conditions will be replaced at no charge to the customers.

Appendix A Software Interface

The GPS-6010-X5 interface protocol is based on the National Marine Electronics Association's NMEA 0183 ASCII interface specification, which is defined in NMEA 0183, Version 2.2 and the Radio Technical Commission for Maritime Services (RTCM Recommended Standards For Differential Navstar GPS Service, Version 2.1, RTCM Special Committee No.104).

A.1 NMEA Transmitted Messages

The GPS-6010-X5 supported by SiRF Technology Inc. also outputs data in NMEA-0183 format as defined by the National Marine Electronics Association (NMEA), Standard.

The default communication parameters for NMEA output are 4800 baud, 8 data bits, stop bit, and no parity.

Table A-1 NMEA-0183 Output Messages

NMEA Sentence	Description
GPGGA	Global positioning system fixed data
GPGLL	Geographic position latitude \ longitude
GPGSA	GNSS DOP and active satellites
GPGSV	GNSS satellites in view.
GPRMC	Recommended minimum specific GNSS data
GPVTG	Course over ground and ground speed

A.1.1 Global Positioning System Fix Data (GGA)

Table A-2 contains the values for the following example:

\$GPGGA,161229.487,3723.2475,N,12158.3416,W,1,07,1.0,9.0,M,, , ,0000*18

Table A-2 GGA Data Format

Name	Example	Units	Description
Message ID	\$GPGGA		GGA protocol header
UTC Time	161229.487		Hhmmss.sss
Latitude	3723.2475		ddmm.mmmm
N/S Indicator	N		N=north or S=south
Longitude	12158.3416		dddmm.mmmm
E/W Indicator	W		E=east or W=west
Position Fix Indicator	1		See Table 5-3
Satellites Used	07		Range 0 to 12
HDOP	1.0		Horizontal Dilution of Precision
MSL Altitude	9.0	Meters	
Units	M	Meters	
Geoid Separation		Meters	
Units	M	Meters	
Age of Diff. Corr.		second	Null fields when DGPS is not used
Diff. Ref. Station ID	0000		
Checksum	*18		
<CR> <LF>			End of message termination

Table A-3 Position Fix Indicator

Value	Description
0	0 Fix not available or invalid
1	GPS SPS Mode, fix valid
2	Differential GPS, SPS Mode, fix valid
3	GPS PPS Mode, fix valid

A.1.2 Geographic Position with Latitude/Longitude (GLL)

Table A-4 contains the values for the following example:

\$GPGLL,3723.2475,N,12158.3416,W,161229.487,A*2C

Table A-4 GLL Data Format

Name	Example	Units	Description
Message ID	\$GPGLL		GLL protocol header
Latitude	3723.2475		ddmm.mmmm
N/S Indicator	N		N=north or S=south
Longitude	12158.3416		dddmm.mmmm
E/W Indicator	W		E=east or W=west
UTC Position	161229.487		hhmmss.sss
Status	A		A=data valid or V=data not valid
Checksum	*2C		
<CR> <LF>			End of message termination

A.1.3 GNSS DOP and Active Satellites (GSA)

Table A-5 contains the values for the following example:

\$GPGSA,A,3,07,02,26,27,09,04,15, , , , ,1.8,1.0,1.5*33

Table A-5 GSA Data Format

Name	Example	Units	Description
Message ID	\$GPGSA		GSA protocol header
Mode 1	A		See Table 5-6
Mode 2	3		See Table 5-7
Satellite Used (1)	07		Sv on Channel 1
Satellite Used (1)	02		Sv on Channel 2
.....		
Satellite Used			Sv on Channel 12
PDOP	1.8		Position Dilution of Precision
HDOP	1.0		Horizontal Dilution of Precision
VDOP	1.5		Vertical Dilution of Precision
Checksum	*33		
<CR> <LF>			End of message termination

(1) Satellite used in solution.

Table A-6 Mode 1

Value	Description
M	Manual—forced to operate in 2D or 3D mode
A	2D Automatic—allowed to automatically switch 2D/3D

Table A-7 Mode 2

Value	Description
1	Fix Not Available
2	2D
3	3D

A.1.4 GNSS Satellites in View (GSV)

Table A-8 contains the values for the following example:

\$GPGSV,2,1,07,07,79,048,42,02,51,062,43,26,36,256,42,27,27,138,42*71

\$GPGSV,2,2,07,09,23,313,42,04,19,159,41,15,12,041,42*41

Table A-8 GSV Data Format

Name	Example	Units	Description
Message ID	\$GPGSV		GSV protocol header
Number of Messages	2		Range 1 to 3
Message Number	1		Range 1 to 3
Satellites in View	07		Range 1 to 12
Satellite ID	07		Channel 1 (Range 1 to 32)
Elevation	79	degrees	Channel 1 (Maximum 90)
Azimuth	048	degrees	Channel 1 (True, Range 0 to 359)
SNR (C/No)	42	dBHz	Range 0 to 99, null when not tracking
....		
Satellite ID	27		Channel 4 (Range 1 to 32)
Elevation	27	degrees	Channel 4 (Maximum 90)
Azimuth	138	degrees	Channel 4 (True, Range 0 to 359)
SNR (C/No)	42	dBHz	Range 0 to 99, null when not tracking
Checksum	*71		
<CR> <LF>			End of message termination

NOTE: Items <4>,<5>,<6> and <7> repeat for each satellite in view to a maximum of four (4) satellites per sentence. Additional satellites in view information must be sent in subsequent sentences. These fields will be null if unused.

A.1.5 Recommended Minimum Specific GNSS Data (RMC)

Table A-9 contains the values for the following example:

\$GPRMC,161229.487,A,3723.2475,N,12158.3416,W,0.13,309.62,120598, ,*10

Table A-9 RMC Data Format

Name	Example	Units	Description
Message ID	\$GPRMC		RMC protocol header
UTC Time	161229.487		hhmmss.sss
Status	A		A=data valid or V=data not valid
Latitude	3723.2475		ddmm.mmmm
N/S Indicator	N		N=north or S=south
Longitude	12158.3416		dddmm.mmmm
E/W Indicator	W		E=east or W=west
Speed Over Ground	0.13	Knots	
Course Over Ground	309.62	Degrees	True
Date	120598		ddmmyy
Magnetic Variation (1)		Degrees	E=east or W=west
Checksum	*10		
<CR> <LF>			End of message termination

(1) SiRF Technology Inc. does not support magnetic declination. All "course over ground" data are geodetic WGS84 directions.

A.1.6 Course Over Ground and Ground Speed

Table A-10 contains the values for the following example:

\$GPVTG,309.62,T, ,M,0.13,N,0.2,K*6E

Table A-10 VTG Data Format

Name	Example	Units	Description
Message ID	\$GPVTG		VTG protocol header

Course	309.62	Degrees	Measured heading
Reference	T		True
Course		Degrees	Measured heading
Reference	M		Magnetic (1)
Speed	0.13	Knots	Measured horizontal speed
Units	N		Knots
Speed	0.2	Km/hr	Measured horizontal speed
Units	K		Kilometers per hour
Checksum	*6E		
<CR> <LF>			End of message termination

(1) SiRF Technology Inc. does not support magnetic declination. All “course over ground” data are geodetic WGS84 directions.

A.2 RTCM Received Data

The default communication parameters for DGPS Input are 9600 baud, 8 data bits, stop bit, and no parity. Position accuracy of less than 5 meters can be achieved with the GPS-6010-X5 by using Differential GPS (DGPS) real-time pseudo-range correction data in RTCM SC-104 format, with message types 1, 5, or 9. As using DGPS receiver with different communication parameters, GPS-6010-X5 may decode the data correctly to generate accurate messages and save them in battery-back SRAM for later computing.

Appendix B Earth Datums & Output Setting

B.1 Earth Datums

The GPS-6010-X5 is built in earth datum with WGS84.

B.2 Setting

B.2.1 Manufacturing Default

Datum: WGS84.

Baud Rate: 4800.

Output: GGA, GSA, GSV, RMC.

B.2.2 Baud Rate and Output Sentences Setting

B.2.2.1 By SiRFDemo Program

1// Connect your GPS-6010-X5 to PC (either COM or USB)

2// Execute SiRFDemo.exe (Program is in the CD)

3// When "Data Source Setup" shows, select the port (COM 1, 2 or 3....) you used, click "OK".

4// Click "Action", select "Open Data Source", Then you will see lots of sentences shows. All the sentences start with \$GPxxxx. This is NMEA protocol. If you do not see these sentences, please click "View", "Select Message", then click "Development". The message will appear. If it still shows nothing, then continue below steps.

5// There is a screen "Selection of Target Receiver Software" might appear, please select "SiRFstar II".

6// Click "Action", Select "Switch to SiRF Protocol". Then you will see SiRF binary and the sentences start with #Time, shows every 4 lines and you can not see the sentences start with \$GP. These sentences are for setting or viewing the GPS receiver's performance. If your software is using standard NMEA protocol, please do the following:

7// Click "Action", Select "Switch to NMEA Protocol". You will see GGA, GSV, GSA and RMC in black and the Baud Rate is 4800. These are the default we put inside the receiver. Please click "OK". Then you can use it as a standard GPS receiver. If your software uses different sentence, please choose the sentences you need.

After above actions, the new setting will be kept in SRAM. If no power supplied to GPS-6010-X5 for more than 30 days, user must re-set again when power on.

B.2.2.2 By other SiRF based demo program

There are a few companies or private website providing some very good demo software.

Appendix C Ordering Information

C.1 Product Options

C.1.1 OutPut Level (or Data)

GPS-6010-X5: RS-232 & TTL (Standard) with 2-meter cable and PS-2 female Connector.

C.1.2 Color Option

BK Black (Standard)
Other Color: by demand

C.2 Accessories

C.2.1 Cables

- A-6011 Com Port connector (For use with standard RS-232 port)
- A-6011-S Standard COM+PS-2 converting to PS-2 connector (Enable standard old GPS receiver to use with PDA or PC)
- A-6012 PDA connector with Cigarette Adapter (850mA)
- A-6013 USB connector (Use with standard GPS-6010-X5)
- A-6013-C RS-232 GPS convert to USB GPS (Enable standard old RS-232 GPS receiver to be uses as USB GPS)
- A-6014 High power adapter, 6-30VDC
- A-6015 Mounting Bracket
- A-6016 Cigarette adapter, must be used with A-6011 or standard COM + PS-2 GPS.
- A-6017 PDA connector with Cigarette Adapter (2A)

Seq.	Part No.	Appl. Model
1	A-6017-A	ASUS A-600
2	A-6017-A1	ASUS A-620
3	A-6017-AR	ACER S60 / N20 series
4	A-6017-AR2	ACER N30
5	A-6017-B	BESTA I-WINNA
6	A-6017-C	Casio E-115
7	A-6017-C1	Casio E-125
8	A-6017-C2	Casio E-200
9	A-6017-D	Dell Axim X-5
10	A-6017-D1	Dell Axim X-3
11	A-6017-E	Eten P603
12	A-6012-G	GSL Xplore G18
13	A-6012-G1	GSL Xplore G88
14	A-6017-H	HP Jornada 52xx / 54xx / 56xx
15	A-6017-HS	HandSpring Treo
16	A-6017-HS1	HandSpring Visor\Prism
17	A-6017-HS2	HandSpring Edge
18	A-6017-L	Siemens LOOX
19	A-6017-LS	Lenovo SP-230
20	A-6017-M	Mitac Mio 528 / 338 / Yakumo Alpha+Delta
21	A-6017-N	NEC 300E
22	A-6017-P	Palm Vx
23	A-6017-P1	Palm / IBM WorkPad 500/505/
24	A-6012-P3	Palm Zire 71/72, Tungsten T\T2\T3
25	A-6017-Q	I-Paq 36xx / 37xx
26	A-6017-Q1	I-Paq 38xx / 39xx / 54xx
27	A-6017-S	Sony N-7xx / S-xx
28	A-6017-S1	Sony T-6xx / NR-xx / SL-xx / SJ-xx
29	A-6017-SM	Siemens SX-45
30	A-6017-T1	Toshiba E-570

Seq.	Part No.	Appl. Model
31	A-6017-T2	Toshiba E-330/740
32	A-6017-X	O 2 – XDA / T-Mobiles – MDA
33	A-6017-X1	MDA II

Remarks: All A-6017 series Cigarette Adapters are up to 2A and with certificate of **CE, FCC** and **e mark** no. **021433**.

All A-6012 series Cigarette Adapters are up to 850mA with certificate of **CE, FCC** and **e mark** too.

C.2.2 PDA Holders

1	A-2001	PDA Holder, Suction Cup, 150mm, Short Arm
2	A-2001-L	PDA Holder, Suction Cup, 150-320mm Adjustable
3	A-2002-B	PDA Holder, Suction Cup, 150mm, Short Arm, Magnetic Pad
4	A-2002-BL	PDA Holder, Suction Cup, 320mm, Long Arm, Magnetic Pad
5	A-2005	PDA Holder, Suction Cup, 150mm, Short Arm, 4-Claw
6	A-2005-BL	PDA Holder, Suction Cup, 320mm Long Arm, 4-Claw
7	A-2006	PDA Holder, Suction Cup, 150mm Short Arm, 3-Claw
8	A-2006-BL	PDA Holder, Suction Cup, 150mm Long Arm, 3-Claw
9	A-2007	PDA Holder, Suction Cup, 150mm Straight Short Arm, 4-Claw
10	A-2008	PDA Holder, Suction Cup, 150mm Straight Short Arm, 3-Claw

C.3 Products Combination

C.3.1 Standard package

GPS-6010-X5 (GPS Receiver) + Documents CD + Warranty Card + quick installation reference.

C.3.2 Other Combination for GPS Application

C.3.2.1 Navigation

GPS-6010-X5 + A-6011 Notebook Navigation (COM version)

GPS-6010-X5 + A-6012-?? PDA Navigation

GPS-6010-X5 + A-6013 Notebook Navigation (USB version)

GPS-6010-X5 + A-6017-?? PDA Navigation

C.3.2.2 Other Popular GPS Application

GPS-6010-X5 + GPS system for Tracking, Security, Fleet Management.....